

# IEA HIA NEWS

## IN THIS ISSUE

The IEA HIA Today  
Page 1

Project Prize Awards  
Page 2

IEA HIA Technology Spotlight  
Page 4

Tech Talk  
Page 5

Task Ink  
Page 7

DiploTech  
Page 14

Message from the Chair  
Page 16

## THE IEA HIA TODAY

The International Energy Agency Hydrogen Implementing Agreement (IEA HIA) is pleased to announce the selection of winners for the inaugural IEA HIA Project Prize, comprising two categories: Technology Demonstration and Fundamental Research. The IEA HIA Prize winner for Technology Demonstration is the IOTHER Project, “Green Hydrogen from Wind and Solar Mobile Applications,” a project of IEA HIA Task 24, Wind Energy and Hydrogen Integration. The IEA HIA Project Prize winner for Fundamental Research is “Fundamental Safety Testing and Analysis of Hydrogen Storage Materials and Systems” (H-25), a project of IEA HIA Task 22, Fundamental and Applied Hydrogen Storage Materials Development.

The IEA HIA Project Prize is awarded:

*For realizing a hydrogen R,D&D project characterized by technical excellence and harmony in international cooperation that contributes to the understanding and advancement of (basic and applied) hydrogen science.*

IEA HIA Project Prize will be formally presented during the World Hydrogen Energy Conference (WHEC 2010) this May in Essen, Germany. Details on date and location of the award ceremony will be available soon. For the full story on each of the IEA HIA Project Prize winners, see pages 2 and 3.



ITHER PROJECT

## SHOWTIME! IEA HIA Outreach Calendar Spring-Fall 2010

EVENT NAME	DATE	PLACE	OUTREACH TYPE
US National Hydrogen Association Conference	4 May	Long Beach, CA, USA	Presentation: Overview of IEA HIA Strategic Plan 2009-2014
WHEC 2010	18 May	Essen, Germany	Dedicated Conference track with Review Lecture and 8 presentations
WHEC 2010	16-20 May	Essen, Germany	WHEC Trade Fair
Briefing to U.S. Congress	June (Date TBD)	Washington D.C., USA	The Hydrogen R.D&D Landscape: Selected IEA HIA Programs and Initiatives
World Energy Council (WEC)	September	Montreal, Canada	Panel: Technology Transfer and the Regulatory Framework
Fuel Cell Seminar	October	San Antonio, TX, USA	Workshop on outcome of Task 18 - Integrated Systems Evaluation (pending confirmation)

IEA HIA  
9650 Rockville Pike  
Suite 3500  
Bethesda, MD  
USA 20814  
Tel: +1 301 634 7423  
Fax: +1 301 634 7426  
[www.ieahia.org](http://www.ieahia.org)

Secretariat Manager:  
Mary-Rose de Valladares  
[mvalladares@ieahia.org](mailto:mvalladares@ieahia.org)

## IEA HIA Project Prize Winner for Technology Demonstration

**The Ither (Infraestructura Tecnológica del Hidrógeno y Energías Renovables) Project, “Green Hydrogen from Wind and Solar Mobile Applications,” a project of IEA HIA Task 24, Wind Energy and Hydrogen Integration - IEA HIA Project Prize winner for Technology Demonstration**

**ITHER, “Green Hydrogen from Wind and Solar Mobile Applications,” is a project of IEA HIA Task 24 - Wind Energy and Hydrogen Integration**, led by Operating Agents Dr. Luis Correas and Mr. Ismael Aso of the Foundation for the Development of New Hydrogen Technologies in Aragón. The Foundation for the Development of New Hydrogen Technologies in Aragón created the Ither Project. The Foundation’s visionary leaders, Mr. Arturo Aliaga (President), and Mr. Javier Navarro, (Vice Chair), are committed to promotion and use of hydrogen as an energy vector. The Ither Project is part of the Foundation’s Hydrogen Master Plan for Aragon, a Spanish region blessed with abundant wind and solar resources.

The Ither project showcases technology infrastructure for hydrogen and renewable energies in a complete demonstration that includes a testing and training facility for photovoltaics, wind energy and hydrogen. The project consists of a three-turbine 635 kW wind farm, a 100kW grid-connected photovoltaic installation and a stand-alone 2.7 kW photovoltaic application. Hydrogen production by PEM and alkaline electrolysers, hydrogen storage (low and high pressure), fuel cells and a turn-key energy management system complete the Ither offering. The annual electricity output from the wind farm is ~950 MWh; the annual electricity output from the photovoltaic arrays is around 160 MWh. Ither hydrogen is used for two mobile applications: 20 hydrogen bikes and a FormulaZero hydrogen kart.

The Ither Project has thousands of visitors each year. It has been the subject of presentations at conferences and events around the world. Major project outcomes are:

1. Wind – Hydrogen, Photovoltaic – Hydrogen: integration tests and optimal sizing
2. Durability and efficiency tests in the hydrogen production chain
3. Characterization and improvement of components: turbine, electrolysers, compressor, etc.
4. Optimization of mixed systems renewable-hydrogen and development of control systems
5. Improvement in grid quality systems, using part of hydrogen generated in engines or fuelcells
6. Hydrogen fuel cells integration for Mobile application
7. Development of guidelines for system operation and maintenance
8. Efficient use of hydrogen for electricity generation, co-generation and tri-generation
9. Technical Training in hydrogen technologies
10. Joint Venture Agreement with a private sector company to develop wind-to-hydrogen solutions in the MW range.

The Ither Project is a compelling case study in “green hydrogen from wind and solar for mobile applications.” It supports the objectives of IEA HIA Task 24 to explore all possible (technical, economic, social, environmental, market and legal) issues related to hydrogen production using electrolysis with wind energy. Importantly, the Ither Project also serves as a replicable model for a fully integrated wind and hydrogen facility.



ITHER CONSTRUCTION

**Fundamental Safety Testing and Analysis of Hydrogen Storage Materials and Systems (Task 22 H-25), a fundamental research project of IEA HIA Task 22, Fundamental and Applied Hydrogen Storage Materials Development - IEA HIA Project Prize winner for Fundamental Research**

**IEA HIA Project Prize Winner for Fundamental Research**

Dr. Bjorn C Hauback is the Operating Agent for Task 22, which consists of some 50 projects and 18 IEA HIA members. Dr. Donald Anton is the Project Leader for **Fundamental Safety Testing and Analysis of Hydrogen Storage Materials and Systems (Task 22 H-25.)** This Project is a collaboration among four countries: Canada, Germany, Japan and the USA. The Project participants are:

- Donald Anton, Savannah River National Laboratory, USA
- Richard Chahine, Université du Québec à Trois-Rivières, Canada
- Daniel Dedrick, Sandia National Laboratories, USA
- Maximilian Fichtner, Forschungszentrum Karlsruhe, Germany
- Nobuhiro Kuriyama, AIST, Japan
- Daniel Mosher, United Technologies Research Center, USA

Task 22 H-25 addresses risk assessment, thermodynamics and chemical kinetics of materials, as well as risk mitigation and prototype systems. Task 22 believes that comfort with hydrogen is very important to the public. To that end, the two overall project goals are: (1) to improve hydrogen storage systems with respect to safety; and (2) to test and evaluate different materials relative to safety issues. Results from safety tests and experiments with different novel hydrogen storage materials and systems are presented in a special safety session held during every Task 22 meeting. Thus, all of the 50+ Task 22 Experts from 18 countries both contribute to and benefit from the Fundamental safety testing and analysis of hydrogen storage materials and systems project. Major project outcomes are summarized below:

- Testing of different novel hydrogen materials with respect to safety. Test results are communicated to Experts during the Task 22 meetings, and are thus important for continued investigations of these materials.
- Development of testing procedure methodology for hydrogen storage materials (heretofore limited).
- Studies and understanding of properties related to safety of selected hydrides in storage systems and tanks.
- Knowledge-sharing among the Project Experts about handling of materials in the laboratory has contributed to improved procedures for handling of samples and enhanced laboratory safety.
- Publications and presentations in hydrogen storage and safety conferences.

In conclusion, the information developed in this project is crucial to the understanding of safety in solid materials for hydrogen storage. Consequently, the Task 22 H-25 Project represents a critical step in the development and introduction of hydrogen storage materials and systems.



IEA HIA TASK 22 H-25 WINNING TEAM HYDROGEN

**IEA HIA TECHNOLOGY SPOTLIGHT:****TASK 23, SMALL-SCALE REFORMERS FOR ON-SITE HYDROGEN SUPPLY (SSR FOR HYDROGEN)****Task 23 At a Glance**

Task 23 looks to establish a basis for harmonization of technology for on-site hydrogen production from hydrocarbons – fossil and renewable. Approved for a three year term in 2006, Task 23 was recently extended for one year to April 2011. The overall objectives of this applied technology task are to:

- to develop a basis for harmonized capacities for the on-site hydrogen reformer unit
- to identify and examine issues related to the promotion of widespread use of on-site hydrogen reformer units
- to develop a global market guide for the use of on-site hydrogen reformers
- to describe the technology link to renewable sources

The diagram below illustrates relationships and variables in the reformer technology supply chain:



RELATIONSHIPS AND VARIABLES IN THE REFORMER TECHNOLOGY SUPPLY CHAIN

Nineteen experts from 15 organizations in 10 countries participate in Task 23. These experts, including seven suppliers, hail predominantly from industry -- testimony to business interest in hydrogen reformer technology.

**Genesis of Task 23**

The starting point for Task 23 was Task 16 – H<sub>2</sub> from Carbon Containing Materials and its Subtask 16C – Small Stationary Reformers for Distributed Hydrogen Production with Minimum CO<sub>2</sub> Emissions. The Subtask C final report identified a number of challenge in system integration and optimization of various components, gas storage, control units and hydrogen dispensers. The report concluded that there was a strong need to continue the harmonized effort to develop on-site reforming for efficient and clean hydrogen production ([www.ieahia.org/pdfs/rapperswil/Task16CFinal.pdf](http://www.ieahia.org/pdfs/rapperswil/Task16CFinal.pdf).)

Task 23 is organized in three subtasks, each of which has a Subtask Leader:

**Subtask 1 Industrial Harmonization (Subtask Leader Esther Ochoa-Fernandez of Norway)**

This subtask seeks to develop a harmonized approach to reformer design that will facilitate industrialization and cost reduction. To this end, Subtask 1 is completing a survey on state of the art technology. A questionnaire requesting data on operation range, delivery conditions, efficiency, reformer technology, product

**Task 23 Members****Denmark****France****Germany****Italy****Japan****Norway****Sweden****The Netherlands****Turkey****United States**

availability, cold and hot start-up, size and weight has been sent to 31 suppliers. The survey will also compare average costs for reformers with 50Nm<sup>3</sup>/hr, 100Nm<sup>3</sup>/hr and 500Nm<sup>3</sup>/hr capacities. Seventeen responses have been received to date.

Subtask 1 is also focusing on equipment standards.

**Task 23 and the Benefits of Standardisation**

Developers, suppliers, researchers/funders and end-users benefit from the existence of norms and standards for size, footprint and capacity. For the developer and supplier, standardization can lead to reduced costs for vital components such as compressors and valves, as well as lower design costs. Subtask 1 will provide researchers and funders with an overview of areas for future research into production by reforming. For the end-user, standardization facilitates installation planning and simplifies system maintenance.

**Subtask 2 Sustainability and Renewable Sources (Subtask Leader Corfitz Nilsson of Sweden)**

This Subtask addresses the question, “given a feedstock, what should you do with it?” This subtask aims to develop systems for fuel diversification and the use of renewable resources. It is analyzing well-to-wheel fuel paths for NG, Diesel, Gasoline Ethanol, FT-Diesel and DME, and conducting a survey on small-scale carbon capture and sequestration that addresses on-site emissions.

**Subtask 3 Market Studies (Subtask Leader Isamu Yasuda of Japan) - Market Studies**

This Subtask facilitates and supports market development through preparation of market studies. Three market segments are being considered: Asia (Japan); North America (California); and North-Europe (Germany).

**Technology Made Simple**

The schematic below illustrates the main components of a small scale reformer (SSR). A refueling station is a typical SSR application.

**Main components of a small scale reformer**

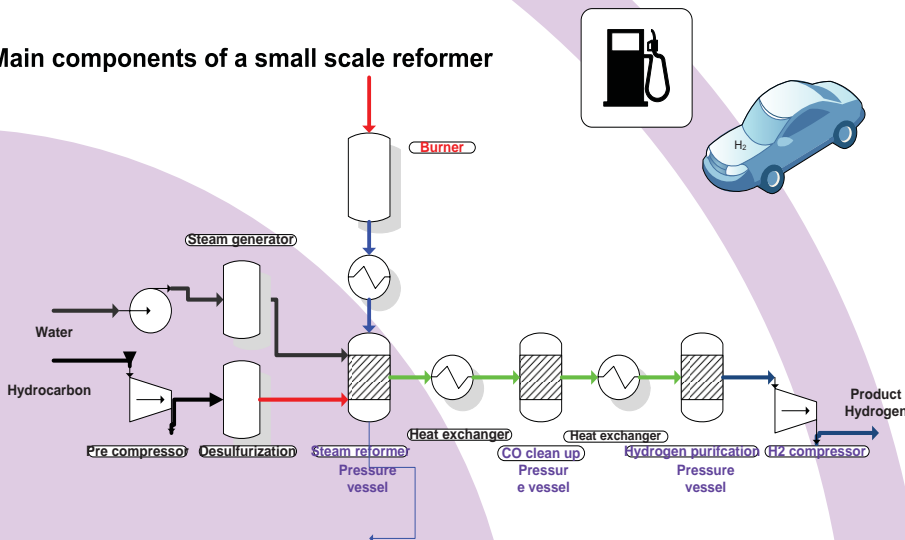

**Tech Talk**



**Dr. Ingrid Schjølberg,** Operating Agent for Task 23, is motivated by results, the kind of results that come from technology development that is important to society, and problem-solving that is useful to industry.

An engineer by training, she stresses that engineering is an essential, applied discipline for technology development. Ingrid holds a Ph.D. in cybernetics – the study of control systems. This generic competency has many possible applications. She received both her Masters and Ph.D. from the Norwegian University of Science and Technology in Trondheim. In 1994, she joined Sintef, one of largest research institutes in Norway, also located in Trondheim. Sintef is a recognized Norwegian leader in industry driven research. There, she first worked with hydropower and profit maximization models for the open electricity market in Europe. She finds the most challenging parts of her work are developing mathematical models and finding enough time to delve into the science of her work (and not just its administration!)

Her leadership role in Task 23 marks Dr. Schjølberg first involvement with the IEA HIA. After all, she comments, “energy is a limited resource and emissions could ruin our world, so these are two compelling reasons for being interested in hydrogen.”

She is pleased with progress in Task 23 as it is becoming increasingly clear that small scale reformers have an important role to play now in the development of a hydrogen infrastructure. They are an important stepping stone in the evolution of distributed refueling systems which will benefit significantly from harmonization of capacities for on-site reformers. The strong support of industry suppliers attests to the value of this work.

# IEAHIA NEWS

## Significant Outcomes

### Subtask 1 Industrialised Harmonisation

The Supplier Questionnaire targets 14 different vendors capable of delivering hydrogen in a broad range of capacities and from various hydrocarbon-based fuels. Task 23 experts are now drawing findings and conclusions from data provided in the survey. The data indicate considerable variation in small scale reformers relative to operation range, delivery conditions, start up times, and footprint for installations in the same production capacity range. This finding confirms the need for a harmonized approach.

Subtask 1 experts have also identified relevant international standards related to the main components of small scale reformers. State of the art procedures and the regulatory costs are likewise under discussion.

### Subtask 2 Sustainability and Renewable Sources

Subtask 2 is demonstrating that SSR can contribute to reduced climate and environmental impact, as well as reduced energy consumption in a well-to-wheel context, while facilitating future large-scale hydrogen introduction. Preliminary findings include :

- Today's fuel cell bus is at least comparable to today's best CNG bus;
- Reformer efficiency (NG to H<sub>2</sub>) must exceed 70% (excluding compression);
- Local solutions provide flexibility;
- While technology for small-scale CCS exists, there is a general consensus that capture from small and mobile sources is costly and will impact efficiency.

### Subtask 3 Market Studies

Market studies analyze the state of the art, challenges and threats in three (3) pivotal marketplaces. They will provide an estimate of hydrogen supply cost, energy efficiency and CO<sub>2</sub> emission on a WTT basis, as well as proof of the advantages of small-scale NG reformers over competing options such as GH<sub>2</sub> transport and supply, LH<sub>2</sub> transport and supply, and on-site water electrolysis. SSR is expected to boost development of H<sub>2</sub> refueling infrastructure and play an important role in early market development. The studies will be completed in 2011.

### Spin-off Benefits

- A harmonised framework for design of refueling stations with on-site production addressing safety issues and technology will facilitate industrialization and reduce costs.
- Barriers, both technical and non-technical, to the introduction of hydrogen in the transport sector are being reduced through advances in hydrogen production systems, including progress in addressing hydrogen safety codes & standards.
- The study of feedstock and possibilities for on-site hydrogen supply, based on suppliers' operation experience, research and development activities will support suppliers of on-site production units in future technology development.
- A market guide based on results from Japan, Europe and California with respect to quality and quantity will facilitate infrastructure development and generate a decision basis for end-users.
- Identification of technical, regulatory, and other market factors that affect market deployment of renewable energy technologies
- A unique global network of suppliers, end-users and research institutes.

## (Tech Talk continued)

Ingrid hails originally from the southern part of Norway. She was influenced in her choice of careers by her father, who was also an engineer. She also learned the love of travel from family since she spent four years of her early life in Ghana. She later lived in Munich and Geneva. Today, she lives in the picturesque town of Trondheim, with her husband, Gunleiv, and their three children: Emilie (13), Sigrid (10) and Tellef (6). She spends as much time with them as possible, crediting the size of the town and the proximity of its facilities, coupled with Norway's family-friendly culture, with enabling her to balance work and family in a satisfying way. This lady clearly gets results on both the home and career fronts!



**IEA HIA Strategic Framework 2009-2014**

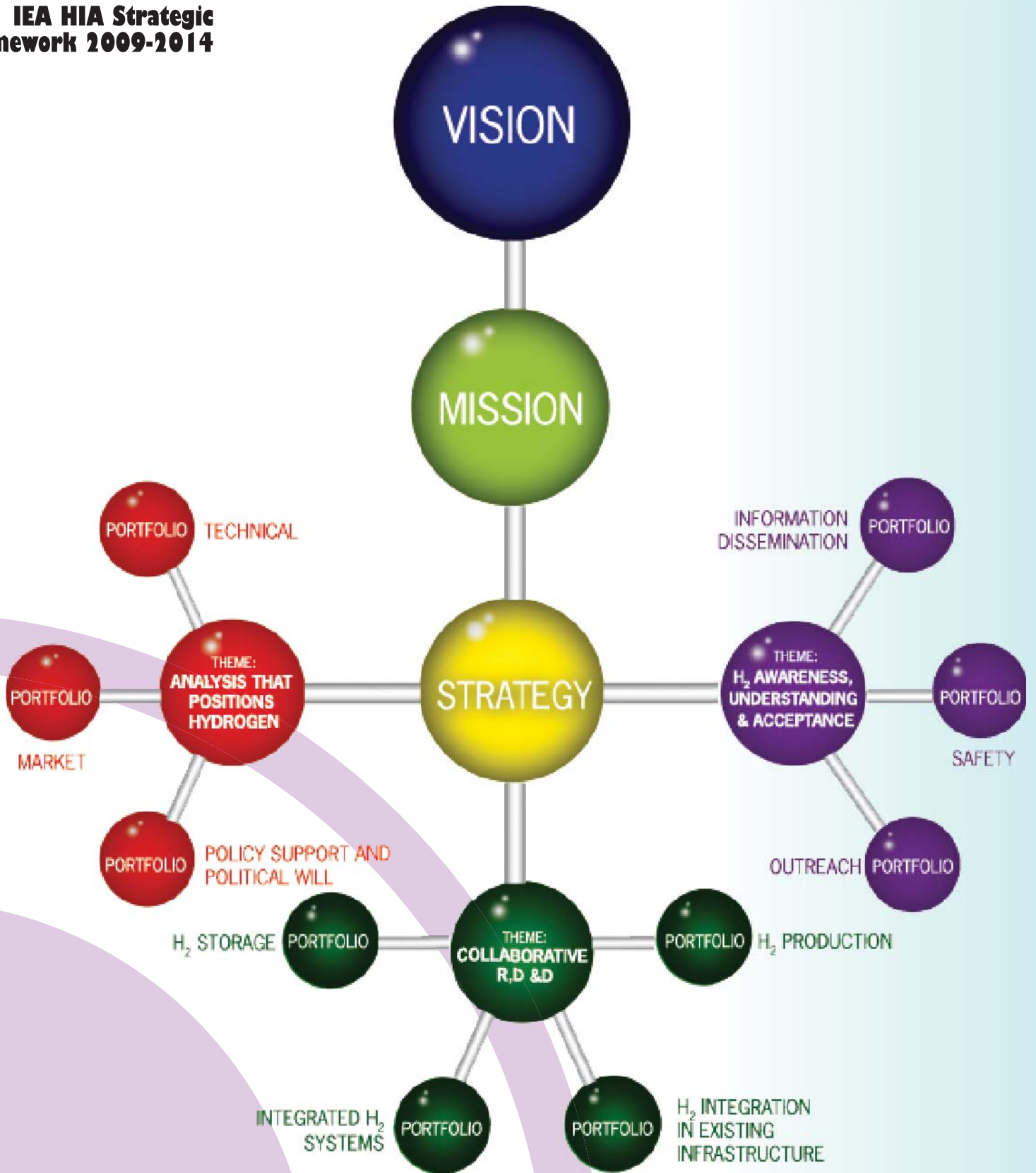

**TASK INK****Hydrogen Production****Current Acts****Task 21, BioHydrogen**

Operating Agent Dr. Jun Miyake

In the words of Operating Agent Dr. Jun Miyake, biohydrogen used to be the “scared little dog” of the research world. Today, however, with the aggressive global growth in the field, “biohydrogen has become a wolf.” At the 62nd Executive Committee meeting Task 21 will formally propose an extension of its current work. To manage increased international interest, regional coordinators will represent North America, the European Union and Asia Pacific.

**Task 23, Small Scale Reformers for Onsite Hydrogen Supply (SSR for Hydrogen)**

Operating Agent Dr. Ingrid Schjøberg

Task 23 is featured in this issue's IEA HIA Technology Spotlight. Please see this article to learn about small-scale reformers for hydrogen, a near-term technology that is expected to contribute significantly to the development of hydrogen infrastructure and early markets for hydrogen. A profile of Operating Agent Dr. Ingrid Schjøberg accompanies the Technology Spotlight.

**Task 24, Wind Energy and Hydrogen Integration**

Operating Agent Mr. Ismael Aso

As reported on pages 1 and 2 of this issue, IHTER, a project of Task 24, has been selected as the winner of the inaugural IEA HIA Project Prize.

In other news, Task 24 has two new participants, Hydrogenics and Statoil. The draft report for Subtask A – State of the Art is now being reviewed internally. Operating Agent Mr. Ismael Aso was an invited speaker at the March 2010 Optimising Energy Storage forum in Beijing, China where he made the case for wind energy and hydrogen integration. Task 24 has recently created a Facebook page and welcomes fans!

**Task 25, High Temperature Production of Hydrogen**

Operating Agent Ms. Sabine Poitou

For the 61st IEA HIA Executive Meeting in Seville, Operating Agent Ms. Sabine Poitou prepared the Task 25 Semi-Annual Report together as well as the proposal for a one year extension from May 2010 to May 2011. As she was unable to attend the Seville meeting, the presentation was delivered by Mr. Paul Lucchese. Subtask A, Scientific & Technological Review, Analysis of High Temperature Processes and State of the Art, is now preparing a recommendation for the future that includes a strategy for supporting HTP deployment. Subtask B, Methodology for HTP Evaluation, is now engaged in the fourth of four steps on application of the HTP evaluation tool to assess the potential of new pathways for hydrogen production vis-à-vis mature processes. A reorientation toward large scale institutional platforms has been adopted for Subtask C, Demonstrator's Needs - Figures of Merit & Future Industrial Deployment

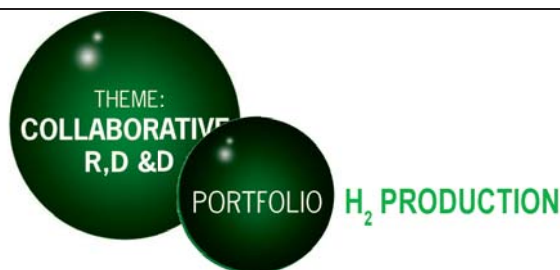
**IEA HIA Portfolio****PAST****Task 1 1977-1988****Thermochemical  
Production****Task 2 1977-1979****High Temperature  
Reactors****Task 3 1977-1980****Assessment of  
Potential Future Markets****Task 4 1979-1988****Electrolytic  
Production****Task 5 1979-1983****Solid Oxide Water  
Electrolysis****Task 6 1979-1988****Photocatalytic Water  
Electrolysis****Task 7 1983-1992****Storage, Conversion, and  
Safety****Task 8 1986-1990****Technical and Economic  
Assessment of Hydrogen****Task 9 1988-1993****Hydrogen Production**

**Task 10 1995-1998****Photoproduction of Hydrogen****Task 11 1995-1998****Integrated Systems****Task 12 1995-2000****Metal Hydrides for Hydrogen Storage****Task 13 1999-2001****Design and Optimization****Task 14 1999-2004****Photoelectrolytic Production****Task 15 1999-2004****Photobiological Production****Task 16 2002-2005****Hydrogen from Carbon Containing Materials****Task 17 2001-2006****Solids and Liquid State Storage****Task 18 2004-2009****Integrated Systems Evaluation****Task 20 2004-2007****Hydrogen from Waterphotolysis**

Strategy. For Subtask D, Communication, 8 out of 15 process flyers have been validated. They include: Alkaline Electrolysis; CDNG; EHT; I/S cycle; Steam Methane Reforming; UT-3 thermochemical cycle; HyS cycle; Zn/ZnO cycle. Soon to be validated are the following: nuclear heat energy; Chloride Family; Metal/Metal oxide; HYDROSOL; Screening AnalySis of Solar. Techno-economic methods will be finalized at the end of the task.

**Task 26, Materials for Photoelectrochemical (PEC) Waterphotolysis**

Task Organizer Dr. Eric Miller

The development of new semiconductor materials meeting all criteria remains the key objective of the photoelectrochemical (PEC) Experts. The main approach of the materials R&D focuses on identifying state-of-the-art theory, synthesis and analysis techniques.

The original task structure, which consisted of: A) PEC Materials Theory; B) Materials Synthesis; C) Materials Characterizations; D) Data Management/Database, has been elaborated to include new expert sub-groups and to add new international experts to the list of distinguished reviewers in the Task 26 standardization effort. A new book on solar hydrogen will feature the contributions of Task 26 Experts.

**Opening Acts****Task 27, Near-Term Market Routes for Hydrogen by Co-Utilization of Biomass as a Renewable Energy Source with Fossil Fuel**

Co-Operating Agents, Dr. Jan-Erik Hanssen and Ms. Asli Kaytaz

In 2009, Task 27 kicked-off with seven IEA HIA members. The development of this task was made possible through the Research Council of Norway's support of Task Organizer, Elisabet Fjermestad-Hagen, and The Netherlands' initial funding of Co-Operating Agent, Dr. Jan-Erik Hanssen through SenterNovem. He and Ms. Asli Kaytaz of the TUBITAK Marmara Research Center in Turkey now serve as Co-Operating Agents for this task, which is a spin-off of Task 16, Hydrogen from Carbon-Containing Materials. The overall objective of Task 27 is to advance the development of hydrogen production based on renewable sources in the market place, focusing on biomass and on opportunities of interest for industrial application. Task 27 seeks to enable "green" hydrogen supply routes at industrial scale using biomass. To this end, Task 27 is tackling the challenges of economies of scale, building a value chain, and simultaneous attention to scaling of upstream and downstream processes.

The specific objectives are to:

- Identify and evaluate the most attractive and realistic process pathways towards a large-scale demonstration of biomass co-gasification with fossil fuels;
- Quantify the potential for a renewable-based H<sub>2</sub> supply chain based on upgrading biomass waste near source into a tradable intermediate (a "biomass carrier"), its commercial transport and use in centralised gasification plants;
- Evaluate the most attractive way of utilising stand-alone biomass gasification technology in near-to-medium term H<sub>2</sub> markets;
- Develop and verify a Roadmap for the market introduction of biomass-based routes to H<sub>2</sub>

## IEAHIA NEWS

**CURRENT****Task 19 2004-2010  
Hydrogen Safety****Task 21 2005-2010  
Biohydrogen****Task 22 2007-2012  
Fundamental and  
Applied H<sub>2</sub> Storage  
Materials Development****Task 23 2007-2011  
Small-Scale Reformers  
for On-site Hydrogen  
Supply (SSR for H<sub>2</sub>)****Task 24 2007-2010  
Wind Energy and  
Hydrogen Integration****Task 25 2007-2011  
High Temperature  
Production of Hydrogen****Task 26 2008-2011  
WaterPhotolysis****Task 27 2008-2011  
Near-Term Market Routes  
to Hydrogen by Co-  
Utilization of Biomass  
as a Renewable Energy  
Source with Fossil Fuels****COMING  
ATTRACTIONS****Task 28 2010-2013  
Large Scale Hydrogen  
Delivery Infrastructure**

Task 27 has four Subtasks:

- Subtask A: Processes for co-gasification (Subtask Leader Dr. C. Zeppi)
- Subtask B: Biomass Tradable Intermediates (Subtask Leader Dr. B. vd. Beld)
- Subtask C: Dedicated Biomass Gasification (Subtask Leader Dr. E. Kurkela)
- Subtask D: Roadmap (Dr. J-E Hanssen)

The fact that Puertollano -- the world's largest gasification plant -- is co-located with Spain's national hydrogen center and co-owned by Elcogas, a major utility actively participating in Task 27, could be highly conducive to progress in this task.

**Hydrogen Storage****Current Act**

**Task 22, Fundamental and Applied Hydrogen Storage and Development** Operating Agent Dr. Bjorn C. Hauback

Task 22 encompasses 49 active projects and 53 active official Experts from 18 countries. Among its projects is the IEA HIA Project Prize winning H-25 "Fundamental Safety Testing and Analysis of Hydrogen Storage Materials and Systems" highlighted on pages 1 and 3. As of year-end 2008 Task 22 had produced 450 publications. Because Task 22 has evolved a very effective system of "Gordon-conference style" meetings that last 4-5 days, the interval between meetings is now 8-9 months instead of 6 months.

Task 22 completed its three year term 1 December. However, further work on materials is still needed. Therefore, the Executive Committee approved the request for a three year extension, which will run from 1 December 2009 to 1 December 2012. During the extension period, Task 22 will focus more on applied storage and its engineering aspects, with greater emphasis on stationary storage and hydrides for other applications. Targets will include development of hydrogen storage materials and systems for other potential energy related applications such as batteries.

**Integrated Systems****Current Acts**

**Task 23, Small Scale Reformers for Onsite Hydrogen Supply (SSR for Hydrogen)**

Task 23, also part of the Integrated Systems Portfolio, is featured in this issue's IEA HIA Technology Spotlight. Tech Talk profiles Operating Agent Dr. Ingrid Schjølberg.

**Closing Acts**

**Task 18, Integration Systems Evaluation**

Operating Agent Dr. Susan Schoenung

Task 18 was completed end-of-December 2009 after six years of highly productive activity that occurred in two three-year phases. There were 15 participants in Phase II. The Task succeeded at its overall goal of providing information about hydrogen integration into society around the world. The Task 18 public Website is located at <http://iea-hia-annex18.sharepointsite.net/Public/>.



The website contains:

- Current contents - Annex 18 Whitepaper, other documents
- List of affiliated members
- National documents, organizations and projects information bases
- Links to case studies and other links

Its achievements are summarized below by Subtask:

#### **Subtask A: Information Base Development**

Includes 282 documents from 18 countries; 269 links from 17 countries; and 106 projects from 17 countries; 20 Task 18 reports; 37 Task 18 case studies; a Literature Search and Analysis on “where will the hydrogen come from.” This information bases will soon be archived on the IEA HIA website.

#### **Subtask B: Demonstration Project Evaluation**

Modeling and simulation of integrated hydrogen demonstration projects of a non-trivial nature including 6 vehicle and refueling systems and 8 stationary power, CHP or infrastructure projects.

#### **Subtask C: Synthesis and Learning**

Compendium of assessments synthesizing learning from Subtask A in seven activities: Practical Lessons Learned; Case studies; Trend Analysis; Comparative & Technical Analysis; Outreach/ Dissemination Activities; Regional & National Plans; Economic Analysis. Eight major reports comprise part of this Subtask’s output.

Distributed and Community Hydrogen, now in definition, is a direct successor to Task 18. Task 18 also contributed substantially to formation of the Global Hydrogen Systems Analysis task, also in definition, and the Large-Scale distribution Infrastructure, which received preliminary approval in 2009. Final approval of all three tasks is expected in the near term.

The Task 18 Final Report will be completed soon and available to the public at no cost on the IEA HIA website at [www.ieahia.org](http://www.ieahia.org) along with other major Task 18 reports.

## **Coming Attractions**

### **Distributed and Community Hydrogen**

The proposed task, Distributed and Community Hydrogen, would be a successor to Task 18, Evaluation of Integration Systems. It seeks to progress the optimisation and replication of “green” hydrogen within distributed and community energy systems where hydrogen is locally, rather than centrally, produced and distributed. The new Task is expected to use a case study approach featuring projects. The scope of distribution and community hydrogen covers: 1) island, rural and urban communities; 2) off-grid or communities connected and interacting with smart grids; 3) communities ranging in size from one building to a subdivision of a city. The proposed areas of analysis are: economic, social, environmental, regulatory, technical and technical. The proposed Task comes to the Executive Committee for review an approval in May..

## H<sub>2</sub> INTEGRATION IN EXISTING INFRASTRUCTURE

### Opening Acts

#### Task 28, Large Scale Hydrogen Delivery Infrastructure

Operating Agent, Marcel Weeda



This new Task, lead by Operating Agent Marcel Weeda of the Netherlands, will hold its Kick-off meeting in Essen, Germany during the World Hydrogen Energy Conference (WHEC) and just before the 62nd IEA HIA Executive Committee Meeting. The Task will focus on the hydrogen delivery infrastructure needed to support demand from large-scale transport applications, especially cars and light duty trucks, and stationary applications such as residential and commercial small-scale combined heat and power. The task objectives are:

1. To establish an international expert group on hydrogen delivery infrastructure issues.
2. To develop a set of key assessment criteria for evaluation of the applicability of different hydrogen delivery concepts in the roll-out of a large-scale hydrogen delivery infrastructure.
3. To develop a state-of-the-art knowledge base on concepts and components for (large-scale) transport and distribution of hydrogen and to identify gaps in knowledge and technology.
4. To share insights and improve understanding of the infrastructure needed to deliver hydrogen based on projections of H<sub>2</sub> penetration for various applications, and the consequences of different strategies for infrastructure roll-out.
5. Support IEA's Energy Technology Policy (ETP) division with up-to-date insights and information in the field of hydrogen delivery infrastructure.

Within the scope defined, Task activities may be directed by research topics that are still open for debate or have not yet been touched upon. Examples could be: Gradual build-up of distribution capacity or installation of full size systems; Storage at hydrogen refuelling stations; Lock-in effects in building up a hydrogen infrastructure; Synergies between hydrogen infrastructures for transport and stationary applications.

## ANALYSES THAT POSITION HYDROGEN

### Coming Attractions

#### Analysis that Positions Hydrogen

The IEA HIA Strategic Plan for 2009-2014 affirms the Agreement's commitment to rigorous, independent analysis that supports collaborative R&D efforts and addresses the larger issue of the transition to the hydrogen economy. This "Analytic Imperative" stimulated our Strategic Plan's theme of "Analysis that Positions Hydrogen." It also resulted in creation of an Analysis Group that will soon transform into a formal IEA HIA Task.



The working goal of the proposed Task is to perform a comprehensive technical and market analysis of hydrogen technologies and resources, including supply and demand, related to the projected use of hydrogen in a low-carbon world with intermittent energy sources. One of its principal objectives would be to prepare authoritative analyses that can be used to answer questions posed by the IEA HIA, HIA Task members, IEA, and government institutions and policymakers about hydrogen sources and uses. Formal Analysis task definition meetings were held in November 2009 and February 2010. The Analysis Task proposal comes to the Executive Committee for review and approval in May 2010.

## H<sub>2</sub> AWARENESS, UNDERSTANDING AND ACCEPTANCE

### Current Act

#### Task 19, Safety

Operating Agent Bill Hoagland

Task 19 is now in its sixth and final year, which will end in October 2010. Task 19 experts have advised the IEA HIA Executive Committee that additional hydrogen safety work remains to be done. Therefore, Operating Agent Bill Hoagland requested and received Executive Committee permission for this cohesive collaboration to go back into the task definition phase. Task Experts believe that their knowledge base and products are crucial for market adoption of hydrogen.

Task 19 reports great success on the outreach front. Due to the generous support the U.S. Department of Energy, the IEA HIA was able to jointly-sponsor the International Conference on Hydrogen Safety 3 (ICH3) with the International Association of HySafe (IA HySAFE). ICH3 was held in Corsica in September 2009. Task 19 Operating Agent Bill Hoagland spearheaded Task 19's contributions to this conference, now the premier world event in hydrogen safety.



# IEA HIA NEWS

## DIPLOTECH

In a winning move, **Canada** sent twenty fuel cell buses to the 2010 Olympics in Vancouver. Olympic organizers gave the buses high marks for performance.

In **Denmark** the Bright Green trade fair held in conjunction with the U.N. Climate Change Conference (COP 15) enjoyed great success. The Danish Gas Technology Center generously supported the IEA HIA's participation in this industry-sponsored event.



BRIGHT GREEN TRADE FAIR AT UN COP 15

The European Union has a new European Parliament and a new Commission. Development of European Energy Policy – based on CO<sub>2</sub> reduction, security of energy supply and EU competitiveness – is a high priority. The EU has mandatory targets for greenhouse gas reduction (20% by 2020), for the share of renewables in energy use (20% by 2020), and for increases in energy efficiency (20% by 2020). The **European Commission** reports that European energy policy is flying high with the adoption of its European Strategic Energy Technology Plan (SET-Plan), which identifies a number of energy technologies with 2020 and 2050 horizons. These technologies have to be further developed in industry-led public-private partnerships, known as European Industrial Initiatives (EIIs). The Fuel Cell and Hydrogen Joint Technology Initiative (FCH-JTI) is considered as a forerunner of the EIIs. SET-Plan also includes SETIS (Set-Plan information system) run by JRC Institute for Energy.

To tackle the current economic and financial crisis, the Commission has launched the European Economic Recovery Plan (EERP), which includes a number of energy technology-related activities on top of the ones described in the SET-Plan: CCS, energy efficiency and the Green Car Initiative. Particularly the latter, with an earmarked 5 B€ budget (out of which 1B€ for R&D), should be streamlined with the FCH-JTI.

**France** has adopted a goal of 23% for renewable energy. The H2E (hydrogen and fuel cell) project will soon launch officially. A lobbying platform has been developed by the General Assembly in Lyon.

**Germany** elected a new coalition for incumbent Chancellor Angela Merkel. While the focus of efforts may change slightly, the new German program on hydrogen and fuel cells is slated to run until 2016. Program will be funded by contributions of 700 M € from both government and industry.

**Japan's** new Prime Minister has stated that Japan will reduce its CO<sub>2</sub> emissions by 25% in 2020. To accomplish this, hydrogen and fuel cells are needed. A significant stationary fuel cell demonstration launches this year involving ~1000 fuel cell systems.

**NEDO** has honored the IEA HIA with a Japanese translation of our End of Term Report 2004-2009 and Strategic Plan 2009-2014. Look for it under What's New on the IEA HIA website.

**New Zealand** has had a change of government. Hydrogen is one of its six priority areas.

In **Norway**, hydrogen funding is stable at the 50 M € level.



DR. LARS VALLANDER

Hydrogen and fuel cells figure prominently in **Spain's** efforts to promote renewable energy. As Spain is quite decentralized, many of the principal Spanish projects are promoted in the frame of regional governments.

Longtime **Swedish** Representative to the IEA HIA, Dr. Lars Vallander, has stepped down from his position on the Executive Committee. He is pictured here with the IEA HIA ExCo's memento gift commemorating his service. His replacement, Mr. Gustav Krantz, is expected to report to the IEA HIA for dirty soon.

**Switzerland** announces the government's intent to reduce CO2 emissions by 40%.

In the **Netherlands**, there is a new WasserstoffNet project with the Flemish government. Other projects continue to progress.

In the **United Kingdom**, 7.2 Million £ in possible technology grant funding will be available through the Technology Strategy Board. The UK is now considering whether and how to make technology choices at the policy level.

New IEA HIA member **UNIDO** ICHET reports that its hydrogen projects are progressing. Acquisition of H2 tanks and other H2 related equipment for the DELHY-3W project (converting 3-wheelers in N. Delhi to run on H2) is underway. The Bozcaada Hydrogen Island Project is also progressing with installation of PV panels and a small wind turbine, along with finalization of the procurement for the hydrogen system. UNIDO ICHET and UNIDO have been assigned a 6.7 MUS \$ GEF contract (3 M US\$ GEF support) for realizing two RES+H2 sites, one on Bozcaada and another on the Cook islands. This technology transfer project will involve networking with existing installations in Norway and Greece, as well as with potential installations in Cape Verde.

The **U.S.** DOE budget item that funds hydrogen activities within the Office of Energy Efficiency and Renewable Energy was ultimately set at the \$174 million level for Fiscal Year 2010. Overall funding for U.S. DOE FY 2010 hydrogen activities – including the Offices of Fossil Energy, Nuclear Energy and Science – is expected to be ~\$243 million.

The U.S. DOE Office of EERE was very pleased to have facilitated cooperation between the IEA HIA and the International Association for Hydrogen Energy (IA HySafe) on the International Conference on Hydrogen Safety (ICH3), which was held on Corsica in September 2009.

The U. S. DOE will hold its Annual Hydrogen Program Merit Review 7-11 June in Washington, D.C. For the first time, this meeting will be held in conjunction with the Vehicle Technologies Program. All are welcome to attend. To register, go to <http://www.annualmeritreview.energy.gov/registration.cfm>.



# IEA HIA NEWS



The IEA HIA News is published twice a year by the International Energy Agency Hydrogen implementing Agreement (IEA HIA), whose vision for a hydrogen future is based on a clean, sustainable energy supply that plays a key role in all sectors of the economy.

## Chairman

**Antonio G. García-Conde**

## Secretariat Manager

Mary-Rose de Valladares

## Message from the Chair

UNIDO's November 2009 accession to the IEA HIA is big news, not just for IEA HIA, but also for the IEA since it marks the first time a United Nations organization has joined any IEA Implementing Agreement. But the news gets even better because the mission of UNIDO ICHET, a UNIDO project and UNIDO's IEA HIA representative, is to "demonstrate viable technologies for the implementation of a hydrogen inclusive economy as well as to develop their widespread use, more particularly in developing countries." UNIDO ICHET's mission intersects squarely with the IEA HIA's mission. And we expect UNIDO ICHET to be an effective bridge to the developing world, where prospects for leapfrogging old technology and energy regimes in favor of hydrogen energy are bright indeed. Dr. Nicolas Lymberopoulos of UNIDO ICHET will represent UNIDO on the IEA HIA Executive Committee. Dr. Mustafa Hatipoglu, UNIDO ICHET Managing Director, will be the Alternate.

This has been a time for transitions. On a bright note, the IEA HIA announces that Mr. Ito Takatsune of the IEA has been named as the new Desk Officer for the IEA HIA. Effective liaison with the IEA is very important to the success of this Agreement. The IEA HIA looks forward to working with Mr. Takatsune.

But on a sad note, the IEA HIA regrets to announce the sudden passing of Dr. Tony Clemens. Dr. Clemens was CRL Energy's General Manager of Research. A sanguine soul, he was an important contributor to New Zealand's hydrogen efforts and to the IEA HIA as well. He is survived by his wife, Joan, his daughter, Stacey, and his mother, Noeleen. He will be missed by us all.

As we go forward in Spring 2010, the IEA HIA has a full outreach calendar. We are very proud to announce that the inaugural IEA HIA Project Prize will be awarded to the Task 24 IOTHER Project, "Green Hydrogen from Wind and Solar Mobile Applications" in the area of Technology Demonstration, and the Task 22 H-25 project "Fundamental Safety Testing and Analysis of Hydrogen Storage Materials and Systems" for Fundamental Research. The award ceremony will take place at WHEC 2010 in Essen. We hope to see you at WHEC for this ceremony as well as for the IEA HIA session on Tuesday 18 May. And please visit us at the IEA HIA exhibit during the WHEC Tradefair. For other opportunities to hear first-hand about the latest developments in IEA HIA R,D&D, please consult the schedule on page 1 of this newsletter. This year, for the first time, our conference season includes an oral presentation at the World Energy Congress in Montreal.

Here's hoping our paths will cross soon!

Sincerely,

**Antonio G. Garcia-Conde**

Antonio G. García-Conde



## In memoriam

Dr. Tony Clemens

**IEA Hydrogen Implementing Agreement (HIA)**

**9650 Rockville Pike**

**Suite 3500**

**Bethesda, MD**